

**RACKMAX II**  
**Stereo Rack-Mount Mixers**

**Operation Manual**



# RACKMAX II

---

## TABLE OF CONTENTS

Input Channel Controls	pg. 2
Master Controls	pg. 3
Input Channel Connections	pg. 4
Master Connections	pg. 5
Modifications	pg. 6
Specifications	pg. 7
Block Diagram	pg. 8
Warranty	

## INTRODUCTION

The **Rackmax II** is the new and improved version of Biamp's industry standard rack-mount mixer. This unique tool is the answer for those applications demanding a mixer with uncompromising features and performance, but where space is limited or portability is important. In only 8 rack-spaces, the Rackmax II provides 12 or 16 input channels, with the type of features normally found only on larger mixing consoles.

Rackmax II features include:

- ◆ discrete transistor preamps for superb sonic quality
- ◆ 5532 and TL072 op-amps for low noise & low distortion
- ◆ 3-band equalization on each input channel
- ◆ four auxiliary sends on each input channel
- ◆ signal present & peak indicators on each input channel
- ◆ patch insert jack on each input channel
- ◆ solo system previews individual channel signals
- ◆ balanced output from stereo mains, mono main, & monitor
- ◆ 600 ohm headphone output monitors stereo mains & solo
- ◆ two stereo returns & one mono return with pan
- ◆ dual ten-segment meters display stereo mains & solo
- ◆ switchable +48 volt phantom power for condenser microphones
- ◆ DC-Out jack provides power for optional external modules
- ◆ 100mm faders on channels and Left & Right Mains
- ◆ 12 and 16 input channel models available

After reading this manual, if you have any questions or need technical assistance, please call BIAMP SYSTEMS toll-free at 1-800-826-1457 (U.S. & Canada).

## INPUT CHANNEL CONTROLS

+15 ● 1 (1)  
-15 ● trim (2)

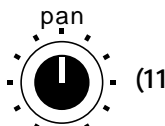
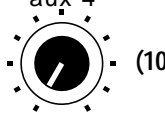
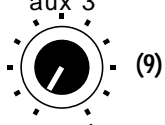
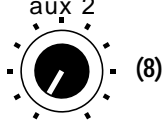
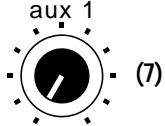
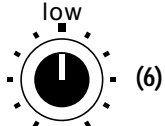
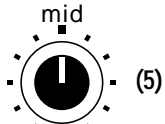
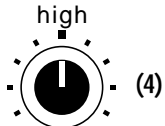

■ solo 1 (12)

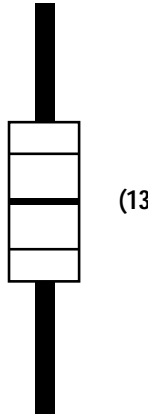

(1) **+15 (Peak Indicator):** This red LED indicates signal level in the channel has reached +15dB (6dB below clipping). For best performance, adjust the Trim control (3) so the Peak Indicator flashes only on occasional peaks.

(2) **-15 (Signal Present Indicator):** This green LED indicates when signal level within the channel is above -15dB (normal levels). Once the Trim control (3) is adjusted, this indicator remains lit when signal is present in the channel.

(3) **Trim:** This control provides 40dB of gain adjustment to compensate for different input signal levels. For best performance, adjust this control so the Peak Indicator (1) flashes only on occasional peaks in signal level.

(4) **High:** This control provides  $\pm 15\text{dB}$  @ 10kHz shelving type equalization.

(5) **Mid:** This control provides  $\pm 12\text{dB}$  @ 2kHz peaking type equalization.

(6) **Low:** This control provides  $\pm 15\text{dB}$  @ 80Hz shelving type equalization.

(7)(8) **Aux 1 & Aux 2:** These controls adjust the level of channel signal sent to the respective auxiliary Send 1 & 2 output sections. The Aux 1 & 2 signals are post-fader and are affected by both channel EQ and Fader settings (see pg. 6 for modification to pre-fader). Post-fader sends are typically used for creating separate mixes to feed effects units.

(9)(10) **Aux 3 & Aux 4:** These controls adjust the level of channel signal sent to the respective auxiliary Send 1 & 2 output sections. The Aux 3 & 4 signals are pre-fader and are affected by channel EQ settings, but not by channel Fader settings (see pg. 6 for modification to post-fader). Pre-fader sends are typically used for creating separate mixes to feed stage monitors.

(11) **Pan:** This control adjusts the relative position of the channel signal between the Left & Right Mains during stereo operation. For mono operation using the Mono output: center this control to provide mono signal to the Mains, or set it full Left or full Right to provide a subgrouping of signals (i.e. instruments on Left Main Fader and Vocals on Right Main Fader), or set it to create a stereo mix at the Left/Right Main and Tape outputs (for recording) while the Mono output is used to feed the sound system (live mix).

(12) **Solo:** This switch sends channel signal to the Solo section for headphone monitoring. Solo is useful for listening to individual channel signals, without interrupting any output mixes. Solo is pre-fader, which permits listening to a channel even when the channel Fader is turned down.

(13) **Fader:** This 100mm slide control adjusts the level of channel signal sent to the Left & Right Main output sections. Channel Fader settings will vary from channel to channel. For best performance, Fader settings in general should center around the "0" mark (unity gain).

# MASTER CONTROLS

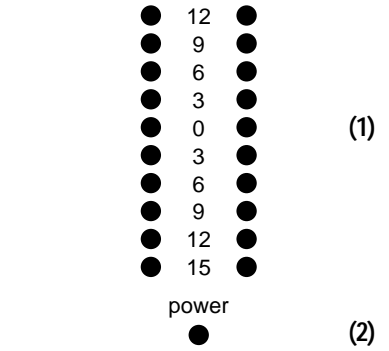

(1) **Level Meter & Power Indicator:** These 10-segment LED displays normally indicate levels at the Left & Right Main Outputs. If the Mains/Solo switch (13) is IN, the Right Level Meter displays signal levels at the Solo system (the Left Level Meter continues to display the Left Main signal level). The +12 indicators flash with 5dB of headroom remaining. These meters are peak reading with "0" referenced to +4dBu.

(3)(4)(5)(6) **Sends 1~4:** These controls adjust the overall level of signal sent from the respective Aux 1~4 channel controls to the Send 1~4 output jacks.

(7)(8) **Returns 1 & 2 (stereo):** These control adjusts the level of signal sent from their respective stereo Return 1 & 2 jacks to the Left & Right Mains.

(9) **Return 3 (mono):** This control adjusts the level of signal sent from the mono Return 3 jack to the Left & Right Mains.

(10) **Return 3 Pan:** This control adjusts the relative position of the Return 3 signal between the Left & Right Mains during stereo operation. When operating in mono and using the Left & Right Mains as submasters, this control can assign an effect to its respective submaster (i.e...vocal delay sent to vocal submaster on Right Main Fader).

(11) **Mono:** This control adjusts the level of signal sent to the Mono jack. This signal is the sum of the Left & Right Main signals (post-Left & Right Main Faders). This becomes the main output level control for the sound system during mono operation. Depending upon channel Pan control settings, the Left & Right Mains may function as submasters for grouping inputs, as additional mono outputs, or as a stereo output for recording.

(12)(14) **Headphones Section:** The Headphones control adjusts the level of signal sent to the Headphones jack. The Headphones output is designed to drive 600 ohm headphones, or to feed a stereo sound system for control room monitoring (see Patch Cable on page 4).

(13) **Mains/Solo:** In the OUT position, this switch selects the stereo signal from the Left & Right Mains to appear at the respective Left & Right Level Meters, and at the Headphones jack. In the IN position, this switch selects mono Solo signals from the channels to appear at the Right Level Meter (for metering individual signals) and at the Headphones jack.

(15) **Left & Right Main Faders:** These 100mm slide controls adjust the level of the Left & Right Main signals sent to the Left & Right Main Output jacks. A sum of the Left & Right Main signals is also sent to the Mono section.

(16) **+48 Volt Phantom Power Switch & Indicator:** This switch applies +48 Volts to all channel Mic inputs for phantom powering of condenser microphones and direct boxes. The red LED remains lit while phantom power is on. Normal low-impedance dynamic microphones are not affected by this voltage. **CAUTION: Always turn levels down before switching phantom power. Always turn phantom power off before making input connections.**

(14) **Power Switch**

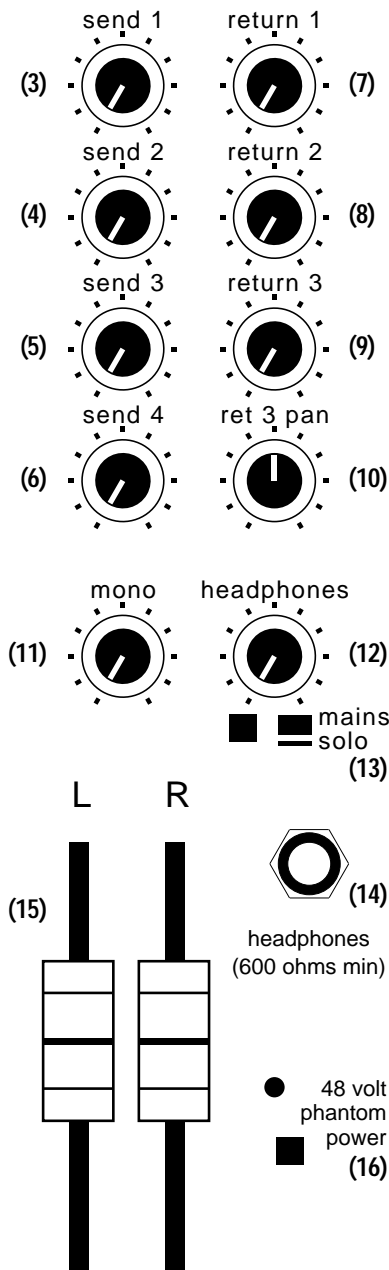

## INPUT CHANNEL CONNECTIONS

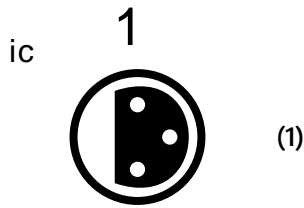

**(1) Mic:** This 3-pin XLR jack provides a balanced transformerless input for connecting low-impedance microphones and direct boxes. It is wired to the DIN standard, with Pin 2 High (+), Pin 3 Low (-), and Pin 1 Ground. When Phantom Power is turned on, +48 Volts is applied to both Pins 2 & 3 of the Mic input jack.



**(2) Line:** This 3-conductor 1/4" phone jack provides for proper connection of either balanced or unbalanced signals from line-level devices such as electronic keyboards, drum machines, effects units, tape decks, wireless microphones, and other mixers. It is wired with Tip High (+), Ring Low (-), and Sleeve Ground. For unbalanced input simply use a standard 2-conductor (TS) 1/4" phone plug wired with Tip High (+) and Sleeve Ground.

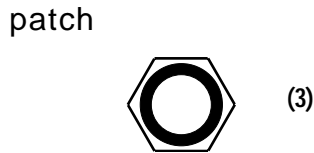

**CAUTION:** The Mic and Line inputs share the same channel circuitry, and connecting to both inputs simultaneously can cause signal interaction.

**(3) Patch:** This 3-conductor 1/4" phone jack provides a post-EQ/pre-fader insert point for connecting outboard signal processing units to the individual channels. A 3-conductor (TRS) 1/4" phone cable inserted into the Patch jack intercepts the channel signal, sends the signal to a processing unit, and returns the processed signal to the channel. The Tip is the send, the Ring is the return, and the Sleeve is ground. Use a standard 3-conductor 1/4" phone cable if the processing unit has a single In/Out jack. Use a special patch cable if the processing unit has separate input and output jacks (see Patch Cable below). Patch jacks may also be used as pre-fader direct outputs to feed other devices, such as multi-track tape recorders, by connecting a 3-conductor cable to the Patch jack with Tip & Ring (wired together) being the send (+) and Sleeve being ground. **NOTE:** Using a standard unbalanced 2-conductor 1/4" phone cable to extract signal from the Patch jack will interrupt the channel signal before it reaches the channel fader.

### PATCH CABLE

This type of cable uses a Tip/Ring/Sleeve (TRS) 1/4" phone connector on one end, and Tip/Sleeve (TS) 1/4" phone (or RCA) connectors on the other two ends. It is wired with Tip A to Tip B, Ring A to Tip C, and Sleeve A to Sleeve B & Sleeve C (ground). This cable is typically used for inserting processed signal into the channel via the Patch jack. Tip B is the send (output) from the channel and Tip C is the return (input) to the channel.

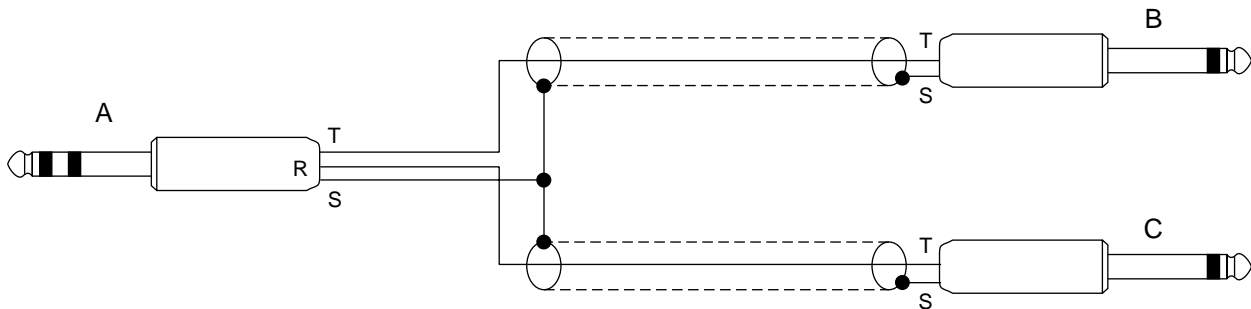

Two other uses for this Patch cable are: 1) To provide a stereo line input to the Return 1 & 2 jacks from stereo effects devices with separate left & right outputs (Tip B connects to the left output of the effects device and Tip C connects to the right output of the effects device). 2) To provide a stereo line output from the Headphones jack for connecting to a stereo sound system (Tip B is the left output and Tip C is the right output).

## MASTER CONNECTIONS

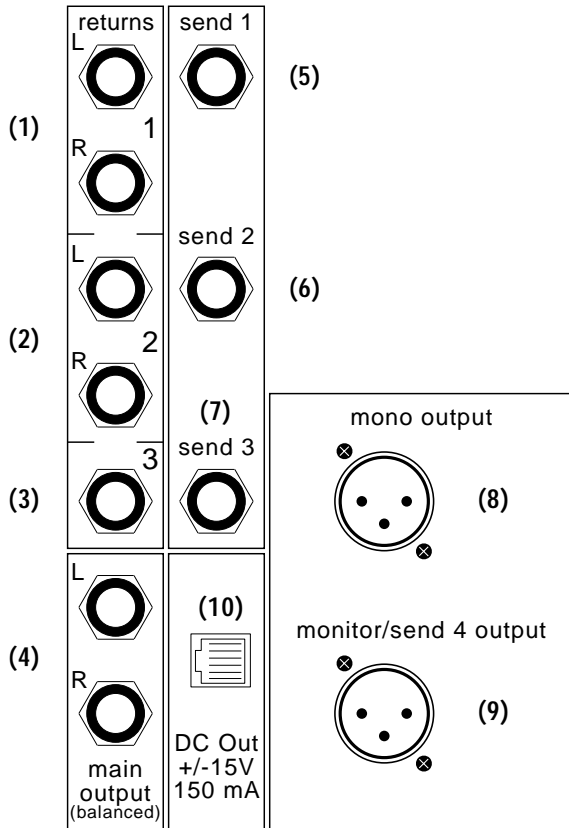

**(1)(2) Returns 1 & 2 (stereo):** These 2-conductor 1/4" phone jacks provide unbalanced stereo inputs for connection of signals from line-level equipment such as effects units, tape decks, and other mixers. The left and right signals from the Return 1 & 2 jacks are sent to the respective Left & Right Mains, via the Return 1 & 2 level controls. Mono signals connected to either the left or right Return 1 & 2 jacks will be sent equally to the Left & Right Mains. Each of the Return 1 & 2 jacks is wired with Tip High (+) and Sleeve Ground.

**(3) Return 3 (mono):** This 2-conductor 1/4" phone jack provides an unbalanced mono input for connection of signals from effects units or other line-level devices. Return 3 signal is sent to the Left & Right Mains via the Return 3 level and Pan controls. Return 3 is wired with Tip High (+) and Sleeve Ground.

**(4) Left & Right Main Outputs:** These 3-conductor 1/4" phone jacks provide proper connection to either balanced or unbalanced line-level inputs on equipment such as sound system amplifiers and tape decks. The Left & Right Main Outputs provide either one stereo output or two mono outputs depending on the settings of the channel Pan controls. The Left & Right Main Output jacks are wired with Tip High (+), Ring Low (-), and Sleeve Ground. For unbalanced output, use standard 2-conductor 1/4" phone plugs wired with Tip High (+) and Sleeve Ground.

**(5)(6)(7) Send 1~3 Outputs:** These 2-conductor 1/4" phone jacks provide unbalanced outputs for connection to effects units or other line-level devices. Send 1~3 Output signals are from the respective channel Aux 1~3 sends. Send 1~3 Outputs are wired Tip High (+) and Sleeve Ground.

**(8) Mono Output:** This 3-pin XLR jack provides a balanced output for connection to line-level inputs on equipment such as sound system amplifiers and tape decks. The Mono Output signal is a sum of all signals present at the Left & Right Main Outputs. This becomes the main output for mono operation, and the Left & Right Mains may function either as submasters, as additional mono outputs, or as a stereo output. The Mono Output jack is wired to the DIN standard, with Pin 2 High (+), Pin 3 Low (-), and Pin 1 Ground. For unbalanced use, connect to the Mono Output jack with Pin 2 High (+) and both Pins 3 & 1 Ground.

**(9) Monitor/Send 4 Output:** This 3-pin XLR jack provides a balanced output for connection to the input of stage monitor amplifiers or other line-level devices. The Monitor/Send 4 Output signal is a sum of all channel Aux 4 signals. The Monitor/Send 4 Output jack is wired to the DIN standard, with Pin 2 High (+), Pin 3 Low (-), and Pin 1 Ground. For unbalanced use, connect to Monitor/Send 4 Output with Pin 2 High (+) and both Pins 3 & 1 Ground.

**(10) DC Out:** This modular jack provides  $\pm 15$  Volts DC (150mA max.) for powering other products (contact Biamp Systems for product information).

**(11) Power Entrance:** This receptacle accepts the 3-prong AC Power Cord. *CAUTION: Do not remove or defeat the ground prong, as this constitutes a shock hazard.* The removable lower portion of the receptacle holds the AC fuse. Replace the AC fuse only with the same value and type (2A SB for "110" VAC operation or 1A SB for "240" VAC operation).

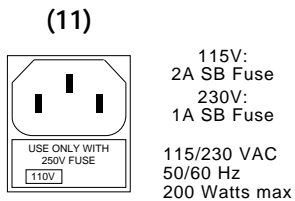

## MODIFICATIONS

**CAUTION:** Modifications should be performed by qualified service technicians only. Care must be taken not to damage any internal parts or circuitry, since this type of damage will not be covered under the product warranty. These modifications require removal of the rear panel only. All circuit boards may remain installed.

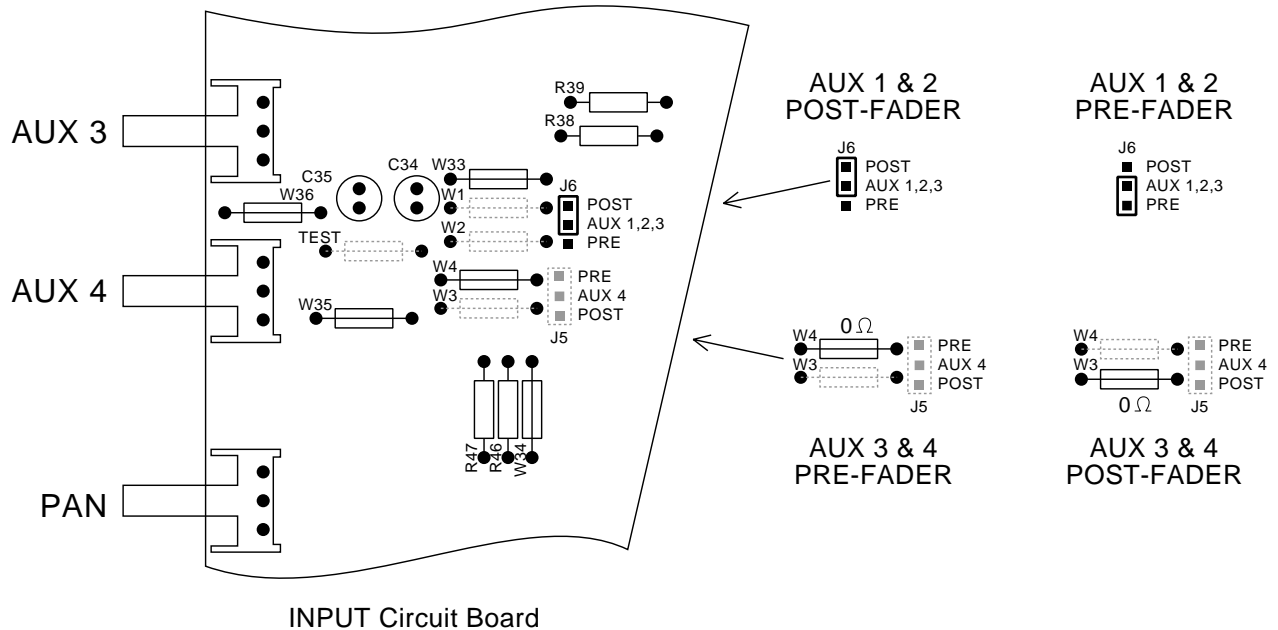

**Aux 1 & 2:** These sends are factory set for post-fader operation. To change Aux 1 & 2 to pre-fader (on a given channel), move jumper strap J6 to the 'PRE' position (see diagram). Aux 1 & 2 are changed as a pair (not individually). Channels must be modified individually.

**Aux 3 & 4:** These sends are factory set for pre-fader operation. To change Aux 3 & 4 to post-fader (on a given channel), move jumper W4 (0 ohm resistor) to the W3 ('POST') position (see diagram). Aux 3 & 4 are changed as a pair (not individually). Channels must be modified individually.

**NOTE:** Other Aux send alternatives are provided on the individual channel circuit boards. For more advanced modifications, please contact Blamp Systems for schematic diagrams and technical assistance.

# SPECIFICATIONS

## MICROPHONE PREAMPLIFIERS:

Frequency Response (20Hz-20kHz @ +4dBu)	+0/-1dB
Total Harmonic Distortion (20Hz-20kHz @ +4dBu, 40dB gain)	< 0.02%
Intermodulation Distortion (SMPTE)	< 0.05%
Equivalent Input Noise (20Hz-20kHz, 150Ω termination)	-127dBu
Maximum Gain (Mic input)	48dB
Maximum Gain (Line input)	31dB
Trim Control Range	40dB
Input Impedance (Mic/balanced)	2kΩ
Input Impedance (Line/balanced)	10kΩ
Maximum Input (Mic)	+11dBu
Maximum Input (Line)	+26dBu
Phantom Power	+48 Volts DC

## INPUT CHANNEL EQUALIZATION:

High EQ	±15dB @ 10kHz
Mid EQ	±12dB @ 2kHz
Low EQ	±15dB @ 80Hz

## MIXER SECTION:

Frequency Response (20Hz-20kHz @ +4dBu)	+0/-1dB
Total Harmonic Distortion (20Hz-20kHz @ +4dBu, unity gain)	< 0.02%
Intermodulation Distortion (SMPTE)	< 0.05%

## INPUT IMPEDANCE:

Returns (unbalanced)	10kΩ
Channel Patch (unbalanced)	3kΩ

## OUTPUT IMPEDANCE:

L/R Mains, Mono, & Monitor/Send 3 (balanced)	200Ω
Sends 1/2 & Channel Patch (unbalanced)	50Ω

## MAXIMUM OUTPUT

L/R Mains, Mono, & Monitor/Send 3 (balanced)	+21dBu
Sends 1/2 & Channel Patch (unbalanced)	+21dBu

## MINIMUM LOAD IMPEDANCE:

L/R Mains, Mono, & Monitor/Send 3 (balanced)	600Ω
Sends 1/2 & Channel Patch (unbalanced)	2kΩ

## HEADPHONES:

Minimum Impedance	600Ω
Maximum Output (each side)	+18dBm (70mW)

**AC POWER REQUIREMENTS (115/230VAC @ 50/60Hz):** 45 Watts max.

## DIMENSIONS:

Height (8 rack-spaces)	14" (356mm)
Width	19" (483mm)
Depth	6" (152mm)

**WEIGHT:** 26 lbs. (11.79kg)



# BLOCK DIAGRAM

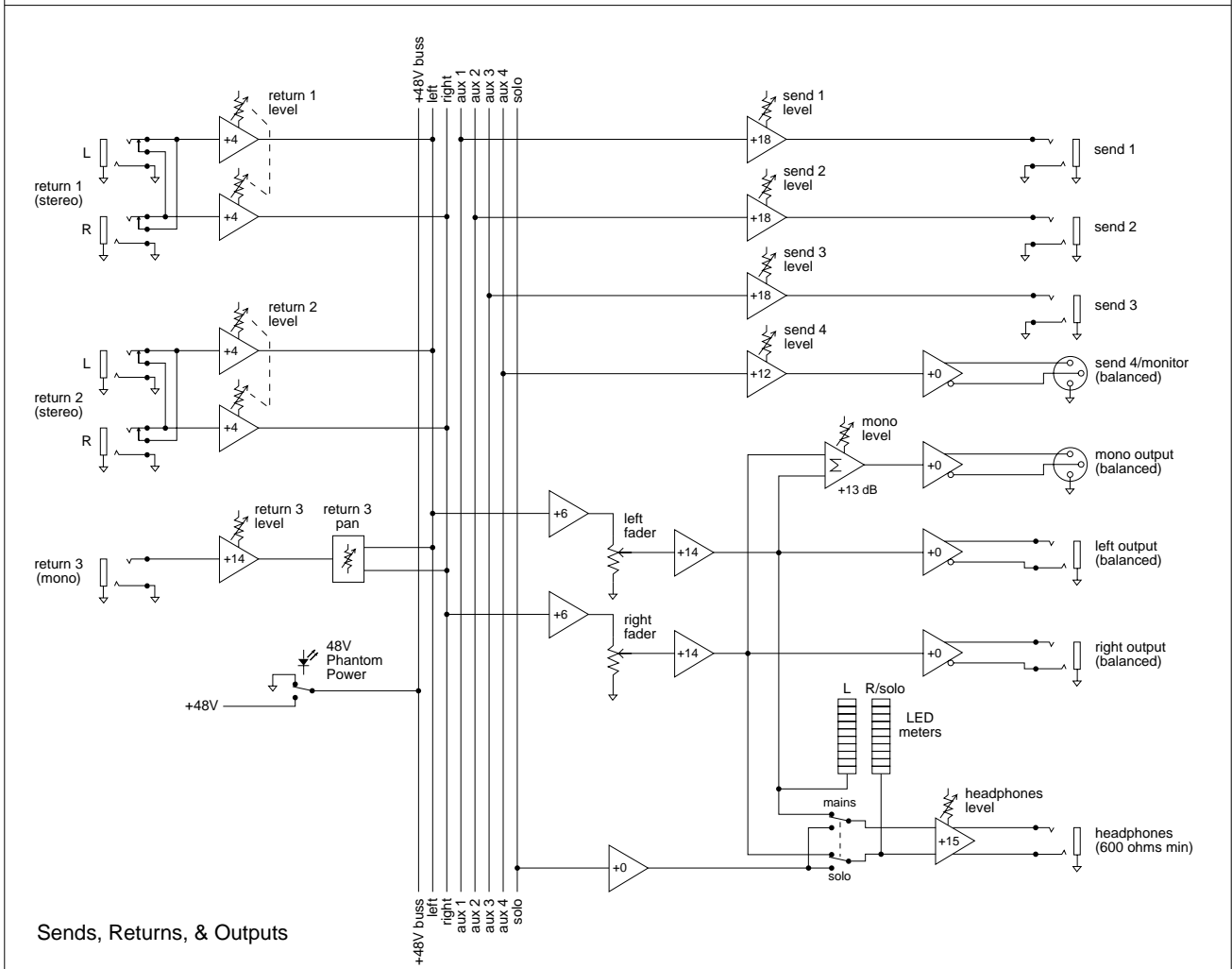
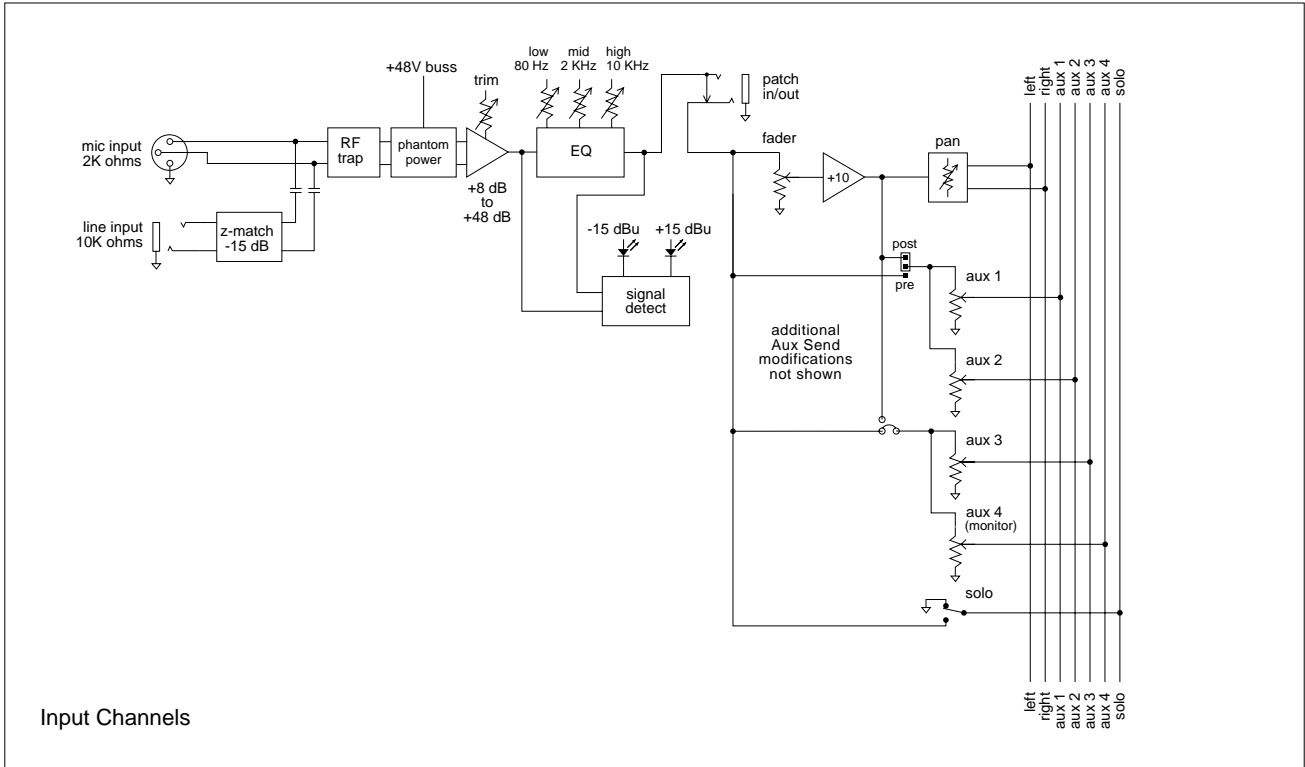

## WARRANTY

---

### BIAMP IS PLEASED TO EXTEND THE FOLLOWING 1-YEAR LIMITED WARRANTY TO THE ORIGINAL PURCHASER OF THE PROFESSIONAL SOUND EQUIPMENT DESCRIBED IN THIS OWNER'S MANUAL.

BIAMP Systems expressly warrants this product to be free from defects in material and workmanship for a period of 1 YEAR from the date of purchase as a new product from an authorized BIAMP dealer under the following conditions.

1. The Purchaser is responsible for completing and mailing to BIAMP, within 10 days of purchase, the attached warranty application.
2. In the event the warranted BIAMP product requires service during the warranty period, BIAMP will repair or replace, at its option, defective materials, provided you have identified yourself as the original purchaser of the product to any authorized BIAMP Service Center. Transportation and insurance charges to and from an authorized Service Center or the BIAMP factory for warranted products or components thereof to obtain repairs shall be the responsibility of the Purchaser.
3. This warranty will be VOIDED if the serial number has been removed or defaced; or if the product has been subjected to accidental damage, abuse, rental usage, alterations, or attempted repair by any person not authorized by BIAMP to make repairs; or if the product has been installed contrary to BIAMP's instructions.
4. The normal wear and tear of appearance items such as paint, knobs, handles, and covers is not covered under this warranty.

5. BIAMP SHALL NOT IN ANY EVENT BE LIABLE FOR SPECIAL, INCIDENTAL, OR CONSEQUENTIAL DAMAGES, INCLUDING LOST PROFITS, LOSS OF USE, PROPERTY DAMAGE, INJURY TO GOODWILL, OR OTHER ECONOMIC LOSS OF ANY SORT. EXCEPT AS EXPRESSLY PROVIDED HEREIN, BIAMP DISCLAIMS ALL OTHER LIABILITY TO PURCHASER OR ANY OTHER PERSONS ARISING OUT OF USE OR PERFORMANCE OF THE PRODUCT, INCLUDING LIABILITY FOR NEGLIGENCE OR STRICT LIABILITY IN TORT.

6. THIS WARRANTY IS IN LIEU OF ALL OTHER WARRANTIES EXPRESSED OR IMPLIED. BIAMP EXPRESSLY DISCLAIMS ALL IMPLIED WARRANTIES OF MERCHANTABILITY AND FITNESS FOR A PARTICULAR PURPOSE. THE REMEDIES SET FORTH HEREIN SHALL BE THE PURCHASER'S SOLE AND EXCLUSIVE REMEDIES WITH RESPECT TO ANY DEFECTIVE PRODUCT. THE AGENTS, EMPLOYEES, DISTRIBUTORS, AND DEALERS OF BIAMP ARE NOT AUTHORIZED TO MODIFY THIS WARRANTY OR TO MAKE ADDITIONAL WARRANTIES BINDING ON BIAMP. ACCORDINGLY, ADDITIONAL STATEMENTS SUCH AS DEALER ADVERTISEMENTS OR REPRESENTATIONS DO NOT CONSTITUTE WARRANTIES BY BIAMP.

7. No action for breach of this warranty may be commenced more than one year after the expiration of this warranty.

Thank you for purchasing BIAMP...  
AMERICAN SOUND CRAFTSMANSHIP

Biamp Systems  
14130 N.W. Science Park  
Portland, Oregon 97229  
(503) 641-7287  
an affiliate of Rauland-Borg Corp.