

DLA93
Digital-Logic
Automixer
Operation Manual

advantage ®

TABLE OF CONTENTS

Front & Rear Panel Features	pgs. 2 & 3
Options	pgs. 4 & 5
Remote Control	pgs. 6 & 7
Logic Outputs	pgs. 8 & 9
Applications	pgs. 10~13
Block Diagram	pg. 14
Specifications	pg. 15
Warranty	

INTRODUCTION

The ADVANTAGE® **DLA93** Digital-Logic Automixer provides nine input channels and three independent outputs, with automatic mixing functions controlled via microprocessor. Input functions such as automixing, phantom power, high-pass filters, and output assignments are selectable on individual channels. The DLA93 includes capabilities for remote control of inputs and outputs, and linking of multiple units for system expansion or room combining.

DLA93 features include:

- ◆ eight mic/line input channels with pad, trim, & peak indicator
- ◆ balanced differential mic/line preamp circuitry (xfmr option)
- ◆ input & direct output for each channel on plug-in barrier strip
- ◆ patch insert point for each channel on TRS 1/4" phone jack
- ◆ phantom power & HPF switch selectable for each channel
- ◆ automatic mixing function switch selectable for each channel
- ◆ output bus assignments switch selectable for each channel
- ◆ level & tone controls, plus active indicator, for each channel
- ◆ additional auxiliary line input channel on plug-in barrier strip
- ◆ aux input switch selectable for balanced or L+R sum signals
- ◆ aux channel includes level, tone, HPF, & output assignment
- ◆ Main, Aux 1, & Aux 2 outputs with independent level control
- ◆ each output balanced on plug-in barrier strip (xfmr options)
- ◆ Aux 1 & Aux 2 switch selectable for pre or post automixing
- ◆ Main output leveler, plus compression on individual channels
- ◆ remote control of inputs/outputs, automixing, & combining
- ◆ logic outputs for active channel control of external switching
- ◆ expansion in & expansion out for linking of multiple DLA93s
- ◆ automixing, linking, & last mic on modes switch selectable
- ◆ active channel hold time switch selectable (0.4 or 1 second)
- ◆ 10-segment meter displays output level or gain reduction
- ◆ front panel security cover included to prevent tampering
- ◆ incorporates **AES** recommended grounding practices
- ◆ **CE** marked and **UL / C-UL** listed power source
- ◆ covered by Five-Year "Gold Seal" Warranty



After reading this manual, if you have any questions or need technical assistance, please call Biamp Systems toll-free **1-800-826-1457**.



FRONT & REAR PANEL FEATURES

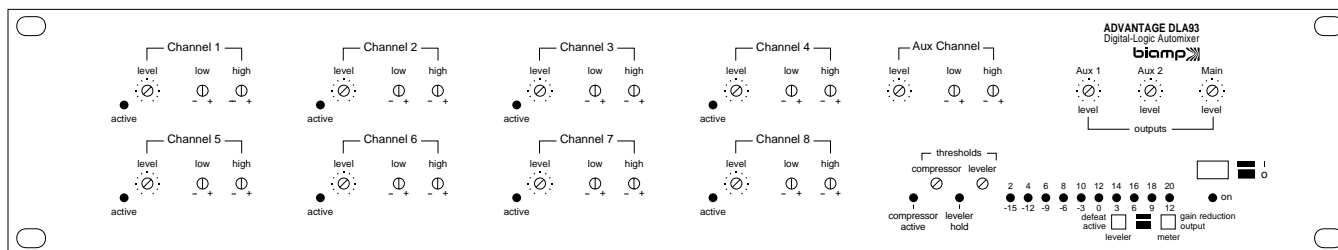

FRONT PANEL FEATURES

Channel Level Controls: These screwdriver adjustable controls set the volume level for Channels 1~8 and the Aux Channel. Level controls affect signals sent to Main, Aux 1, & Aux 2 outputs, as well as Channel 1~8 Direct Outputs. **NOTE:** Volume levels are also affected by an internal VCA (post-Level), which performs automixing, compression, & remote control at specified outputs.

Channel Low & High Controls: These screwdriver adjustable controls set the tone for Channels 1~8 and the Aux Channel. Low provides ± 15 dB of gain for frequencies below 50Hz (bass). High provides ± 15 dB of gain for frequencies above 15kHz (treble).

Channel Active Indicators: These red LEDs indicate when Channels 1~8 are active. If automixing is enabled, this indicator will light only when sufficient signal is present to activate the channel. If automixing is defeated, this indicator will remain lit.

Channel Compressor: Channels 1~8 each have their own independent compressor circuit. The screwdriver adjustable Threshold control sets one standard volume level at which any of the channel compressors will be activated. The adjacent red LED will light whenever any channel compressor circuit is activated.

Output Level Controls: These screwdriver adjustable controls set the volume level for Main, Aux 1, & Aux 2 outputs. Main volume level may also be affected by the Output Leveler circuit.

Output Leveler & Meter: The Main Output section includes a Leveler circuit, which compensates for changes in the average volume level. If the volume level increases, the Leveler reduces gain. If the volume level decreases, the Leveler increasing gain. A Leveler Hold circuit prevents gain changes during pauses, as indicated by the adjacent red LED. The Meter will display either output level or gain reduction, determined by the Meter Switch. To set output level & Leveler operation: **1)** Set the Meter Switch to 'Output'. **2)** Once channel levels are set, adjust the Main Level control for desired level (peaks of +12dB on the Meter are recommended). **3)** Set the Meter Switch to 'gain'. **4)** Adjust Leveler Threshold for amount of gain reduction (6~8dB on the Meter is usually adequate). **5)** Set Meter Switch back to 'Output' **6)** Re-adjust Main Level to compensate for gain reduction (use Leveler On/Off Switch & Meter for comparison). **NOTE:** The Leveler may be defeated with the On/Off Switch, or simply by setting the Threshold control fully clockwise.

Power Switch & On Indicator: When the Power Switch is depressed, the adjacent red LED will light indicating power to the mixer is On. Release the Power Switch to turn power off.

REAR PANEL FEATURES

NOTE: 'Pre-VCA' means signals are not affected by automixing, compression, & remote control. 'Post-VCA' means they are.

Channel Input & Direct Output: These plug-in barrier strips provide the balanced mic/line input to the respective channels. For balanced input, wire high to (+), low to (-), and ground to (▼). For unbalanced input, wire high to (+) and ground to both (-) & (▼). Input isolation transformers are optional (see Options on page 4). Unbalanced channel Direct Outputs (post-Level) are available using (d out) & (▼). Direct Outputs are pre-VCA, but may be changed to post-VCA (see Options on pg. 4).

Channel Trim, Pad, & +10 Indicator: The Trim controls adjust gain at the respective inputs to compensate for different signal levels. For best performance, set Trim so the +10 Indicator is activated only by occasional peaks in signal level. Depress the Pad switch when input signal levels exceed normal operating range of the Trim control, or when line-level input is desired.

Channel Patch: These 3-conductor 1/4" phone jacks are for connection of other Advantage products (or signal processors) to the respective channels. Patch jacks are wired with Tip as send (output), Ring as return (input), and Sleeve as a common ground. Patch cables can be wired for direct output (pre-Level & pre-VCA).

Channel DIP Switches: These six-gang DIP switches assign specific functions to the respective channels. To assign a function, move the corresponding switch upwards. On turns the channel on steadily (defeats automixing). P Pwr enables +24 Volt DC phantom power. **CAUTION:** Assign P Pwr only on channels using condenser microphones which require phantom power. HPF enables a high-pass filter (6dB/oct. @ 170Hz). Main sends post-VCA signal from the channel to the Main output. Bus 2 sends pre-VCA signal from the channel to Bus 2 (see Options on pg. 4). Bus 1 sends post-VCA channel signal to Bus 1 (see Options on pg. 4). **NOTE:** Main, Bus 2, & Bus 1 signals are all affected by the channel level controls (post-Level). The factory default settings are with all DIP switches down, except Main.

FRONT & REAR PANEL FEATURES

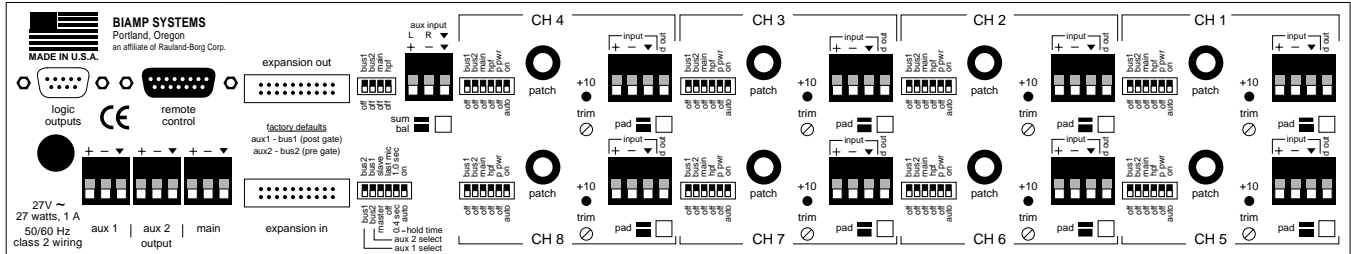

Aux Input & Bal/Sum Switch: This plug-in barrier strip provides the line-level input to the Aux Channel. The Bal/Sum Switch selects either balanced (mono) or unbalanced (summing) input. For balanced input, wire high to (+), low to (-), and ground to (▼). For unbalanced input, wire highs to (L) & (R), and ground to (▼). This can be a stereo signal, two mono signals, or a single mono signal. Summing combines (L) & (R) into a single mono signal.

Aux DIP Switch: This four-gang DIP switch assigns specific functions to the Aux Channel. To assign a function, move the corresponding switch upwards. **HPF** enables a high-pass filter (6dB/oct. @ 170Hz). **Main** sends Aux Channel signal to the Main output. **Bus 2** sends Aux Channel signal to Bus 2. **Bus 1** sends Aux Channel signal to Bus 1. **NOTE: Main, Bus 2, & Bus 1 signals are affected by the Aux Channel Level control (post-fader).** The factory default settings are with all DIP switches down.

Master DIP Switches: This six-gang DIP switch assigns specific functions to the mixer as a whole. To assign a function, move the corresponding switch upwards. **On** turns Channels 1~8 on steadily (automixing off). **1.0 Sec** assigns a Hold Time of one second. Hold Time selects how long an active automix channel will remain on, once signal is no longer present in the channel. **Last Mic** allows the most recently active automix channel to remain on (without signal present) until the next automix channel becomes active. **Slave** sets the mixer as a secondary unit, when linking multiple mixers within a system (see Expansion Out & Expansion In). **Bus 1** sends the Bus 1 (post-VCA) signal to the Aux 2 output (see Options on pg. 4). **Bus 2** sends the Bus 2 (pre-VCA) signal to the Aux 1 output (see Options on pg. 4). The factory default settings are with all DIP switches down.

Expansion Out & Expansion In: These 20-pin headers are for linking multiple mixers within a system. A 20-pin cable harness is provided with each mixer. To link mixers, simply connect the cable harness from Expansion In of one mixer to Expansion Out of the next mixer. Linking mixers increases input capacity and allows room combining. The first mixer within a system is assigned as the 'master'. The 'master' collects audio signals & control data from the other mixers, which are assigned as 'slaves'. They in turn receive appropriate signals & data from the 'master'. Main, Aux 1, & Aux 2 output signals, plus NOM attenuation, are common to all mixers. However, each mixer has independent Output Level, Remote Control, & Leveling. In room combining applications, the 'master'/'slave' assignments are changed via remote switches or contact-closures (see Remote Control).

Remote Control: This 15-pin Sub-D connector allows remote control of the mixer. Level control of Channels 1~8, Aux Channel, Main Output, & Aux 1 Output are provided, as well as selection of automixing & master/slave modes (see Remote Control on pg. 6).

Logic Outputs: This 9-pin Sub-D connector provides Logic Outputs from Channels 1~8, plus a common ground. When a channel becomes active, the corresponding Logic Output goes on. Logic Outputs may be used to control external switching circuits, such as relays or other Advantage products. These outputs are typically used to turn off speakers or select cameras when certain microphones are active (see Logic Outputs on pg. 8).

Main Output: This plug-in barrier strip provides the balanced Main output from the DLA93. For balanced output, wire high to (+), low to (-), and ground to (▼). For unbalanced output, wire high to (+) and ground to both (-) & (▼). An isolation transformer is optional for Main Output (see Options on pg. 4). Main Output signals are always post-VCA from the channels. When multiple DLA93s are used, Main Output signal is affected by Expansion Out & Expansion In (see above).

Aux 1 Output: This plug-in barrier strip provides the balanced Aux 1 output from the DLA93. For balanced output, wire high to (+), low to (-), and ground to (▼). For unbalanced output, wire high to (+) and ground to both (-) & (▼). An isolation transformer is optional for Aux 1 Output (see Options on pg. 4). Aux 1 Output signals are normally post-VCA from the channels, but may be changed to pre-VCA (see Master DIP Switches above, and Options on pg. 4). When multiple DLA93s are used, Aux 1 Output signal is affected by Expansion Out & Expansion In (see above).

Aux 2 Output: This plug-in barrier strip provides the balanced Aux 2 output from the DLA93. For balanced output, wire high to (+), low to (-), and ground to (▼). For unbalanced output, wire high to (+) and ground to both (-) & (▼). Aux 2 Output signals are normally pre-VCA from the channels, but may be changed to post-VCA (see Master DIP Switches above, and Options on pg. 4). When multiple DLA93s are used, Aux 2 Output signal is affected by Expansion Out & Expansion In (see above).

AC Power Cord: The transformer provides 27 VAC (1A max.) to the DLA93, and is detachable via a 5-pin DIN connector. If blown, two internal 'self-resetting' fuses will attempt to re-set after a short period. Continued blowing of these fuses may be an indication that the DLA93 requires service.

OPTIONS

To disassemble the DLA93 and perform any of the following modifications: 1) Disconnect the DLA93 from AC power. 2) Remove the front panel (three screws along top edge & three screws along bottom edge). 3) Remove chassis top (two screws along bottom edge of each side panel & three screws along back edge of top panel). 4) Remove top circuit board (six screws along front edge, six screws along back edge, one screw near center towards right side & three wire harnesses on right edge). 5) Detach bottom circuit board (six stand-offs along front edge, six stand-offs along back edge, & one stand-off near center towards right side). The bottom circuit board cannot be removed without also unsoldering the AC power transformer wires. Instead, the circuit board may simply be tilted upwards to access the bottom for soldering components. The following descriptions & diagrams are oriented with the rear panel towards the user.

Input Isolation Transformers: Input isolation transformers are a user installed option for Channels 1–8 (Model IT-A #909-0010-01).

To install input transformers: 1) Locate transformer positions on the circuit boards, in front of each Input connector (T101 for Channel 1; T201 for Channel 2; etc.). See diagram on next page. Channels 1–4 are on top circuit board. Channels 5–8 are on bottom circuit board. 2) Remove two jumpers (0 ohm resistors) from each transformer position (R104 & R106 for Channel 1; R204 & R206 for Channel 2; etc.). 3) Insert the transformer pins through the holes on the top side of the circuit board, with pin 1 (red dot) of each transformer corresponding to the square solder pad. 4) Solder all six pins on each transformer, at the under-side of the circuit board.

Output Isolation Transformers: Output isolation transformers are a user installed option for Main & Aux 1 (Model IT-B #909-0019-00).

To install output transformers: 1) Locate transformer positions on the bottom circuit board, in front of the Expansion In connector and the Master DIP switches (T9 for Main; T10 for Aux 1). See diagram on next page. 2) Remove two jumpers (0 ohm resistors) from each transformer position (J201 & J202 for Main; J101 & J102 for Aux 1). 3) Install jumper (0 ohm resistor) at new position (J203 for Main; J103 for Aux 1). Use jumpers (0 ohm resistors) previously removed. 4) Insert the transformer pins through the holes on the top side of the circuit board, with pin 1 (red dot) of each transformer corresponding to the square solder pad. 5) Solder all six pins on each transformer, and both leads of each new jumper, at the under-side of the circuit board.

Channel Direct Output Pre/Post Jumpers: From the factory, the channel Direct Output signals are pre-VCA (not affected by automixing, compression, or remote control). However, each channel Direct Output may be individually modified to provide post-VCA signal (including automixing, compression, & remote control).

To convert Direct Outputs to post-VCA: 1) Locate jumper positions on the circuit boards, in the second group of resistors behind each channel High control (J103 & J104 for Channel 1; J203 & J204 for Channel 2; etc.). See diagram on next page. Channels 1–4 are on top circuit board. Channels 5–8 are on bottom circuit board. 2) Move existing jumper (0 ohm resistor) to the vacant 'POST' position (J103 to J104 for Channel 1; J203 to J204 for Channel 2; etc.). 3) Solder both leads of each jumper, at the under-side of the circuit board.

Channel Bus 1 & Bus 2 Pre/Post Jumpers: From the factory, channel signals assigned to Bus 1 are post-VCA (affected by automixing, compression, & remote control) and channel signals assigned to Bus 2 are pre-VCA (not affected by automixing, compression, & remote control). However, each channel may be individually modified to provide pre-VCA signal to Bus 1 and/or post-VCA signal to Bus 2.

To convert Bus 1 to pre-VCA: 1) Locate jumper positions on the circuit boards, in the second group of resistors behind each channel High control (J107 & J108 for Channel 1; J207 & J208 for Channel 2; etc.). See diagram on next page. Channels 1–4 are on top circuit board. Channels 5–8 are on bottom circuit board. 2) Move existing jumper (0 ohm resistor) to the vacant 'PRE' position (J108 to J107 for Channel 1; J208 to J207 for Channel 2; etc.). 3) Solder both leads of each jumper, at the under-side of the circuit board.

To convert Bus 2 signal to post-VCA: 1) Locate jumper positions on the circuit boards, in the second group of resistors behind each channel High control (J105 & J106 for Channel 1; J205 & J206 for Channel 2; etc.). See diagram on next page. Channels 1–4 are on top circuit board. Channels 5–8 are on bottom circuit board. 2) Move existing jumper (0 ohm resistor) to the vacant 'POST' position (J105 to J106 for Channel 1; J205 to J206 for Channel 2; etc.). 3) Solder both leads of each jumper, at the under-side of the circuit board.

Aux Input Bus 1 & Bus 2 Pre/Post Jumpers: From the factory, Aux Input signals assigned to Bus 1 are post-VCA (affected by remote control) and Aux Input signals assigned to Bus 2 are pre-VCA (not affected by remote control). However, the Aux Input may be modified to provide pre-VCA signal to Bus 1 and/or post-VCA signal to Bus 2.

To convert Bus 1 to pre-VCA: 1) Locate jumper positions near the center of the top circuit boards, in front of the Aux Input connector (J903 & J904). See diagram on next page. 2) Move existing jumper (0 ohm resistor) to the vacant 'PRE' position (J904 to J903). 3) Solder both leads of the jumper, at the under-side of the circuit board.

To convert Bus 2 signal to post-VCA: 1) Locate jumper positions near the center of the top circuit boards, in front of the Aux Input connector (J901 & J902). See diagram on next page. 2) Move existing jumper (0 ohm resistor) to the vacant 'POST' position (J901 to J902). 3) Solder both leads of the jumper, at the under-side of the circuit board.

OPTIONS

Input Isolation Transformers

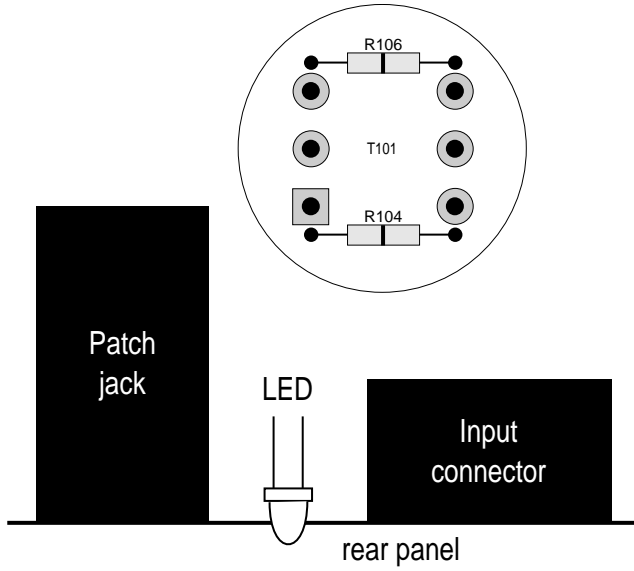

Channel Direct Output and Bus 1 & Bus 2 Pre/Post Jumpers

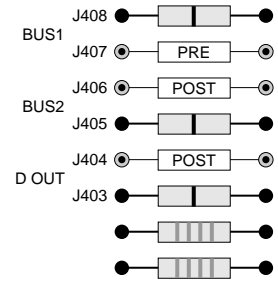

Output Isolation Transformers

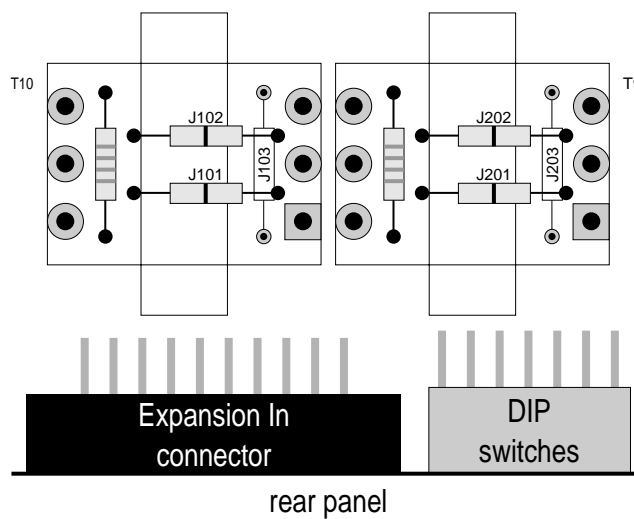

Aux Input Bus 1 & Bus 2 Pre/Post Jumpers

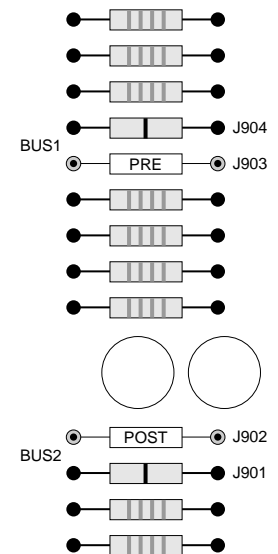

REMOTE CONTROL

The DLA93 provides remote control terminals on a rear panel 15-pin Subminiature D (female) connector. Remote Control can be used with devices such as switches, potentiometers, resistors, diodes, and even Logic Outputs to perform a variety of remote control functions. These devices may be wired up to 2000 feet from the DLA93, and can be configured for functions such as: level adjustment & muting for individual or grouped inputs/outputs; manual/automatic 'chairman override' of multiple inputs; manual/automatic 'page-override' of music input; multi-level 'priority override'; selection of automatic/manual mixing; room combining; etc. See diagrams on next page for some examples of remote control wiring for specific applications.

Remote Control terminals are provided for Channels 1~8, Aux Channel, Main Output, and Aux 1 Output (see diagram below). These terminals have internal pull-up resistors, which keep them at a high idle state of +10 Volts. Therefore, no Remote Control connections are necessary to keep these signals turned on. However, a variable control voltage (0~+10 VDC) can be used to control these signal levels (+10 VDC = unity gain; 0 VDC = -80dB). The DLA93 provides +10V and ground terminals (for use with potentiometers), but an external 'ramp' voltage may be used instead. Potentiometers should be 25kΩ linear taper (Biamp #170-0001-20), and are wired with the high-side to +10V, the wiper to the desired control terminal(s), and the low-side to ground (see diagrams on next page). The wiper of a single potentiometer may be wired to multiple control terminals (to control a group of signals). However, wipers from multiple potentiometers should not be connected to a single control terminal (causes undesirable interaction). Switches, Logic Outputs, or other contact-closures are used to provide muting of the input/output signals, by simply shorting the respective control terminal(s) to ground (see diagrams on next page). A switch may be wired to multiple control terminals (to mute a group of signals). Multiple switches may be wired to a single control terminal, but if multiple switches are connected to multiple control terminals a diode matrix may be necessary (see diagram on next page). The combination of potentiometer & switch can be used to perform level adjustment & muting, or to provide an adjustable amount of 'ducking' attenuation. Use of the DLA93 Logic Outputs in conjunction with the Remote Control terminals can provide various 'automatic' functions. Many other possible uses of the Remote Control terminals exist, which are not mentioned here.

Two additional Remote Control terminals are provided, which allow master/slave assignment and selection of automatic/manual mixing. These terminals have internal pull-up resistors, which keep them at a high idle state of +5 Volts. Switches or other contact-closures are used to short these terminals to ground. The master/slave terminal provides the same function as the 'slave' switch on the DLA93 rear panel (see Master DIP Switches on pg. 3). **NOTE:** *The rear panel DIP switch must be in the down ('master') position for the Remote Control terminal to function.* When multiple DLA93s are linked together, shorting the master/slave terminal to ground assigns the DLA93 as a 'slave' unit. This is effective in room combining applications, where the sound system can be configured manually via a remote switch panel or automatically via contact-closures on the room partitions (see diagram on next page). The auto/manual terminal provides the same function as the 'on' switch on the DLA93 rear panel (see Master DIP Switches on pg. 3). **NOTE:** *The rear panel DIP switch must be in the down ('auto') position for the Remote Control terminal to function.* Shorting the auto/manual terminal to ground selects manual mixing (defeats automatic mixing). This is effective for selecting attended or un-attended operation of the DLA93 (see diagram on next page). It is also possible to select automatic mixing (to manage increased inputs) only when multiple DLA93s are 'combined'.

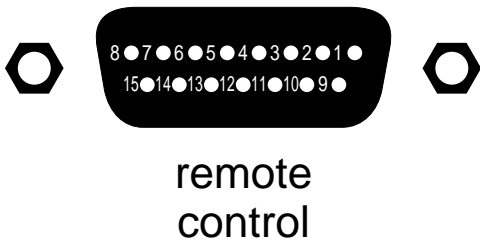

remote control	pin number
channel 1	pin #1
channel 2	pin #2
channel 3	pin #3
channel 4	pin #4
channel 5	pin #5
channel 6	pin #6
channel 7	pin #7
channel 8	pin #8
aux channel	pin #9
main output	pin #10
aux 1 output	pin #11
+10V	pin #12
master/slave	pin #13
auto/manual	pin #14
ground	pin #15

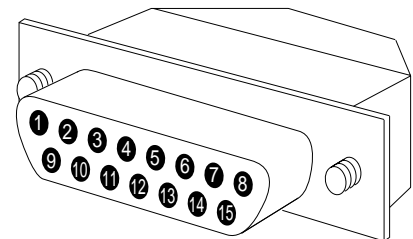

15-pin cable-end

REMOTE CONTROL

Channel 1 Level

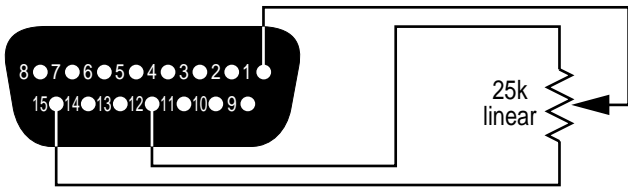

Channel 1 Adjustable Mute 'Ducking'

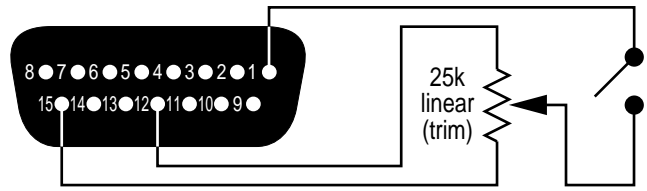

Channels 1~4 Group Level

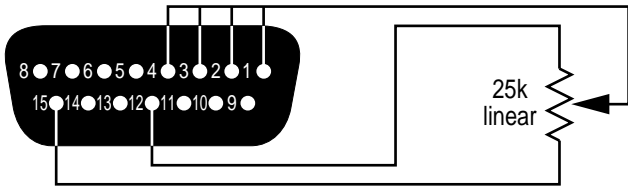

Channels 1~3 Multi-Priority Mute 'Page Override'

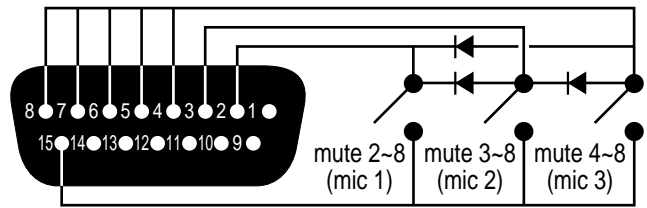

Main Output Level

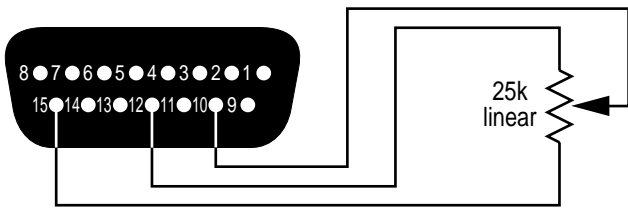

Automatic/Manual Mixing Switch

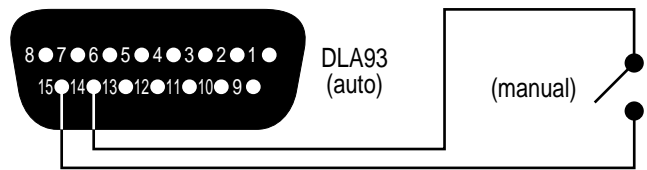

Channel 1 Mute

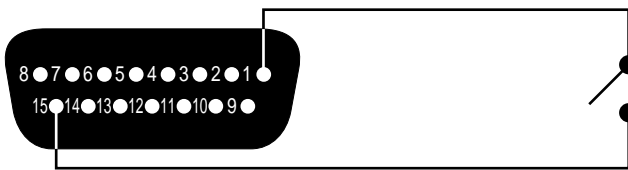

Master/Slave 'Room Combining' Switches

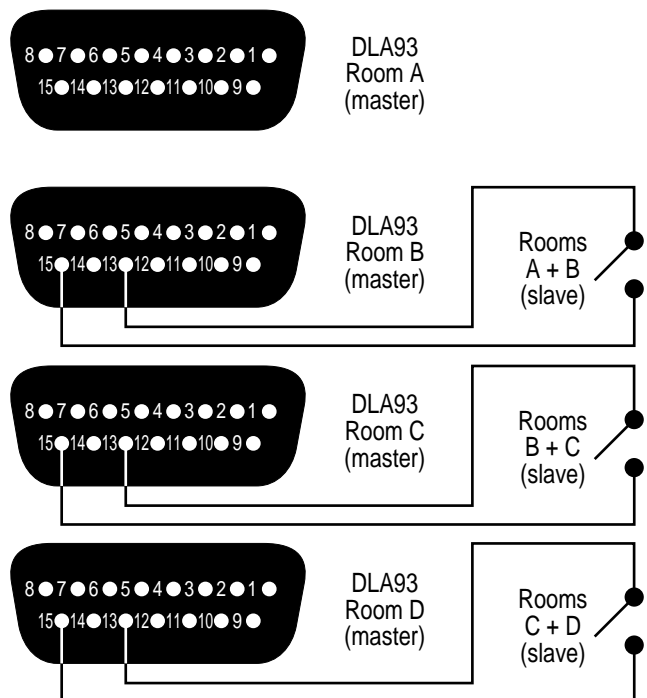

Channels 2~8 Group Mute 'Override'

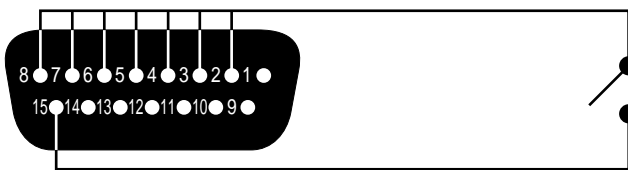

Channel 1 Level & Mute

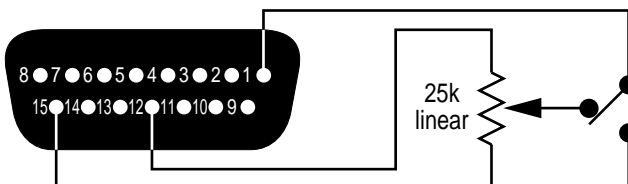

LOGIC OUTPUTS

The DLA93 provides eight logic outputs on a rear panel 9-pin Subminiature D (male) connector. Logic Outputs can be used to control external switching circuits (such as relays) for speakers, cameras, indicators, etc. The DLA93 Logic Outputs are most often used, in conjunction with external relays, to turn off specific speakers when nearby microphones are active (reducing feedback problems). For example, if a speaker is located directly above microphone #1, the Logic Output for Channel 1 of the DLA93 can be used to turn off that speaker relay when microphone #1 is active (see diagram on next page). The Logic Outputs can also be combined (wired in parallel) to control a single circuit. For example, a speaker relay could be turned off when either microphone #1 or microphone #2 is active. In addition to speaker relays, the DLA93 Logic Outputs may be used to control external indicator lights (see diagram on next page). Another common application for Logic Outputs is to control video cameras. Different cameras could be activated depending upon which microphone (or group of microphones) is currently active. Cameras can be selected (using a video switcher such as a VSX41) and/or camera presets may be triggered (using a 'pan/tilt/zoom' camera system). The DLA93 Logic Outputs may also be used in conjunction with the DLA93 Remote Control to perform such functions as 'automatic priority', which allows a microphone (or group of microphones) to be muted whenever specific 'priority' microphones are active (see diagram on next page). The Logic Output for the 'priority' microphone is wired to the Remote Control terminals for the microphones to be muted. A similar approach is useful for 'page-over-music' applications. However, in this case the Logic Outputs from multiple 'paging' microphones are wired to the Remote Control terminal for a single music source to be muted. Multi-level priority schemes are also possible, but may require a diode matrix. These 'priority' applications require Last Mic to be disabled. Of course, manual muting of microphones is also possible (see Remote Control on page 6).

The DLA93 Logic Outputs are 'open collector' outputs. Each Logic Output is an NPN transistor with the collector being the output and the emitter being ground (see diagram on next page). When a Logic Output is turned on, the transistor provides a path for DC current to flow. The Logic Outputs do not provide any voltage or current. They act only as switches (with a common ground return). To activate external relays, an external power supply must be used (see diagram on next page). The Logic Output transistors are rated up to a maximum of 24 VDC and 50 mA per output (24 volt relay coils maximum). However, +12 Volts DC is sufficient power for most applications. When using the Logic Outputs to control relays, protection diodes must be used to suppress high voltage transients that are generated when the relays turn off (see diagram on next page). Any of the 1N4004 family of diodes (1N4001, 1N4002, 1N4003, 1N4004, 1N4005, 1N4006, 1N4007, or equivalent) will provide proper protection. A 12 Volt Power Supply (#909-0011-00), 12 Volt Relays (#520-0064-00), and 1N4004 Diodes (#190-0003-09) are available from Biamp Systems. When a Logic Output goes on, the associated relay may be wired to perform on, off, or 'A/B' switching functions. To use logic 'on' to turn on (or activate) a device, wire across the 'normally open' relay contacts, in series with the device (or control voltage source). To use logic 'on' to select between 'A' or 'B' signals (inputs or outputs), wire one signal to the 'normally closed' relay terminal and the other signal to the 'normally open' relay terminal, with the common relay terminal providing the feed (input or output).

The 9-pin Subminiature D connector used for the DLA93 Logic Outputs is the same type of connector used for RS-232 communications ports on IBM compatible computers (PCs). Most retail computer stores carry 'modem' cables for the IBM PC. These cables have a 9-pin female connector on one end and a 25-pin male connector on the other end. If the cable has full RS-232 modem support, it may be used as a Logic Output cable for the DLA93 by simply cutting off the end with the 25-pin connector. A cable that provides full RS-232 modem support will have either 9 conductors or 8 conductors plus a shield. Pin #5 on the DLA93 was chosen as ground because many of the pre-fabricated modem cables connect pin #5 to the cable shield (IBM AT uses pin #5 as ground). An ohm-meter can be used to easily determine which wires go to which pins of the 9-pin female connector. Of course, a custom cable may be created by simply wiring to the proper pins of a female 9-pin Subminiature D cable-end connector.

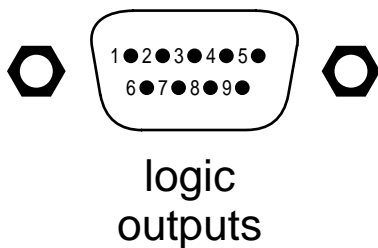

logic out	pin number
channel 1	pin #1
channel 2	pin #2
channel 3	pin #3
channel 4	pin #4
ground	pin #5
channel 5	pin #6
channel 6	pin #7
channel 7	pin #8
channel 8	pin #9

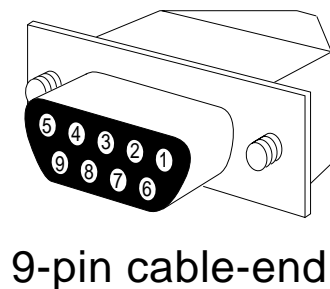

LOGIC OUTPUTS

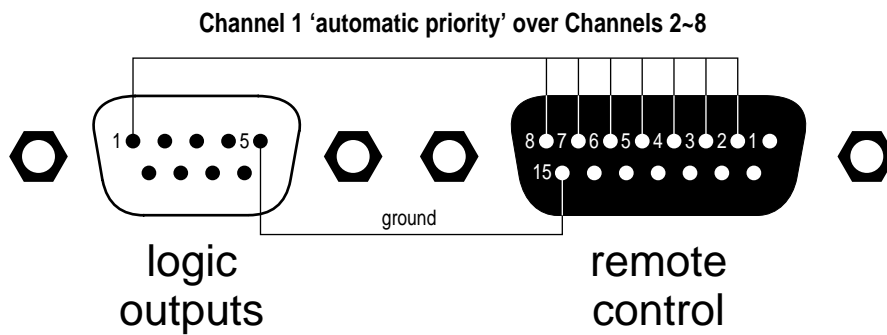
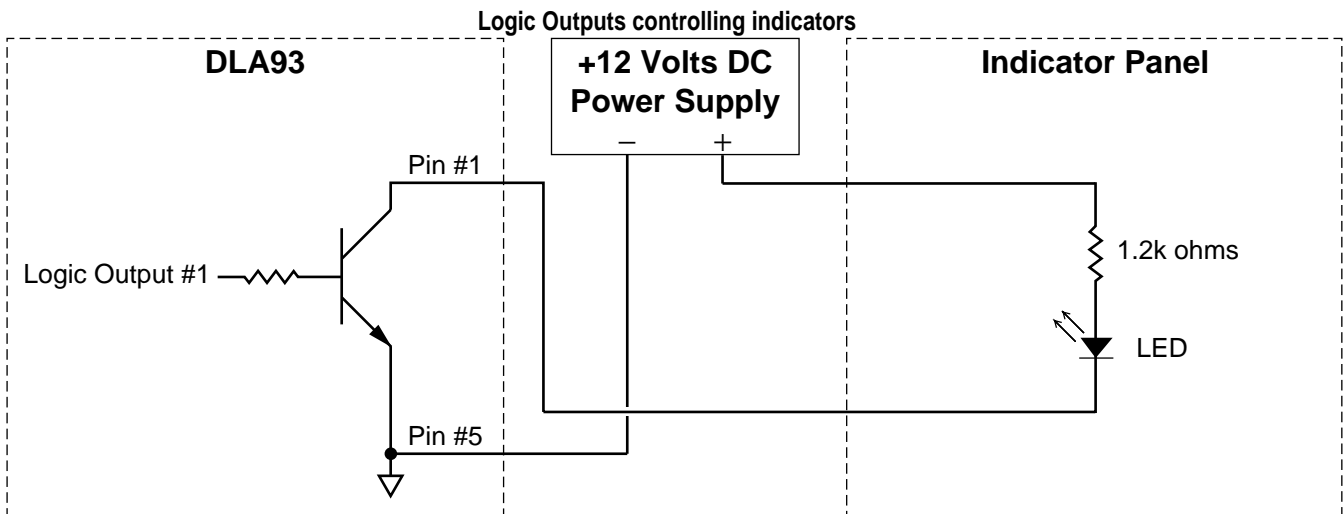
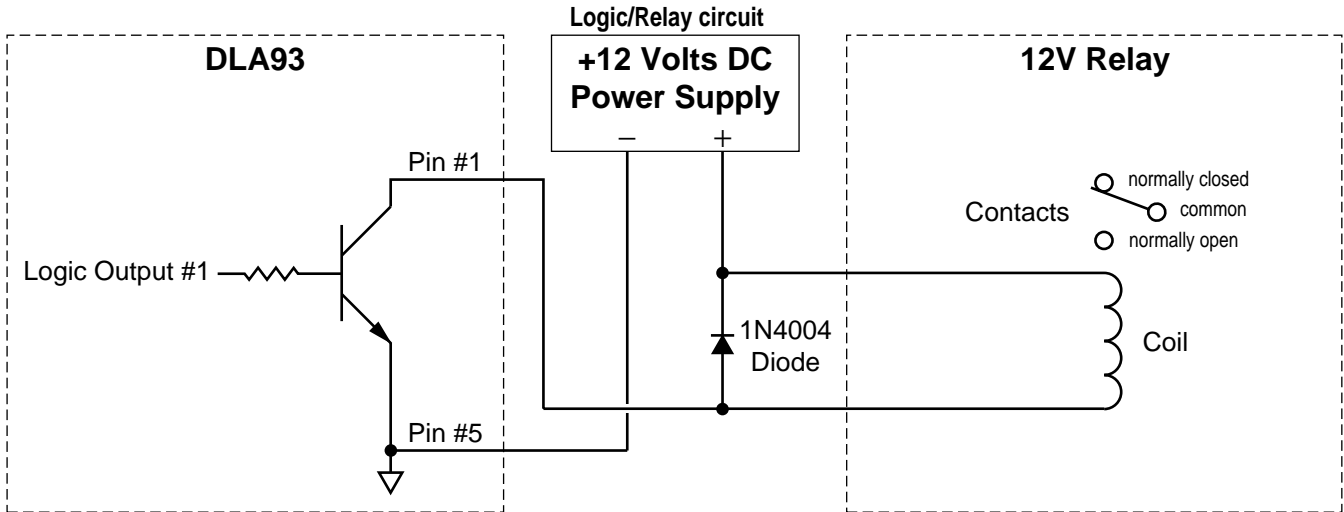

APPLICATIONS

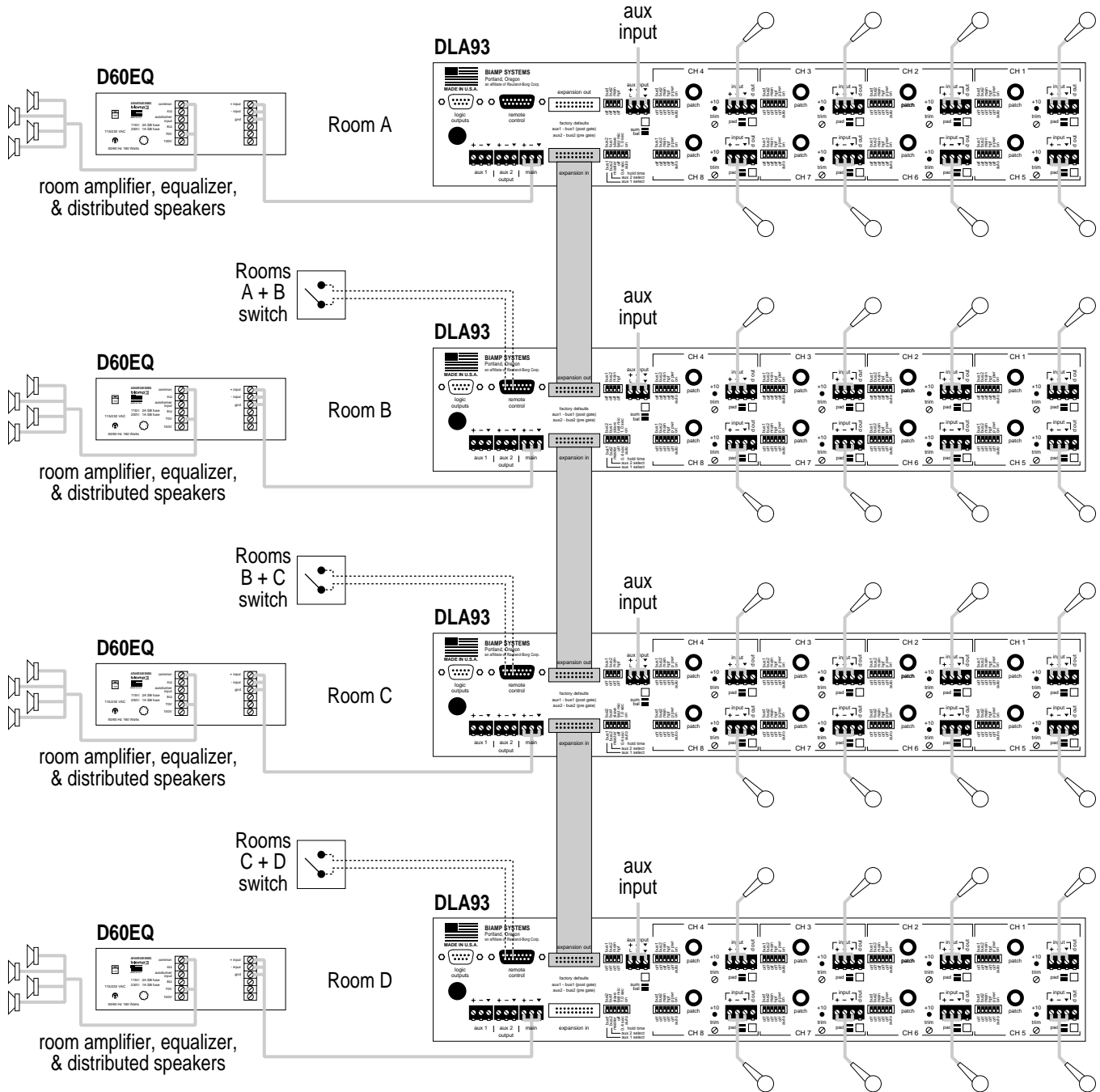

ROOM COMBINING

This application shows four meeting rooms. Each room has an independent sound system, with a DLA93 providing automatic mixing of the eight mics plus an auxiliary input, and a D60EQ providing equalization & amplification for the distributed speaker system. The four DLA93s are 'linked' from Expansion Out to Expansion In, using the 20-pin cable harnesses provided. Each DLA93 is assigned as a 'master' mixer via the rear panel DIP switch. This allows each room mixer to function independently. However, switches wired to the DLA93 Remote Control terminals in Rooms B, C, & D allow those units to be remotely switched to 'slave'. When a DLA93 is switched to 'slave', its audio signals & control data are sent along to the next 'master' DLA93 in the chain. The combined audio signals & control data are then sent back to all 'slaves' of that 'master'. This allows various combinations of the room sound systems. The combining switches may be located on a control panel (for manual room combining), or may be installed on the room partitions (for automatic room combining). **NOTE:** Rooms A & D cannot be 'linked' (combined). Therefore, this application works best for rooms which are in a row.

APPLICATIONS

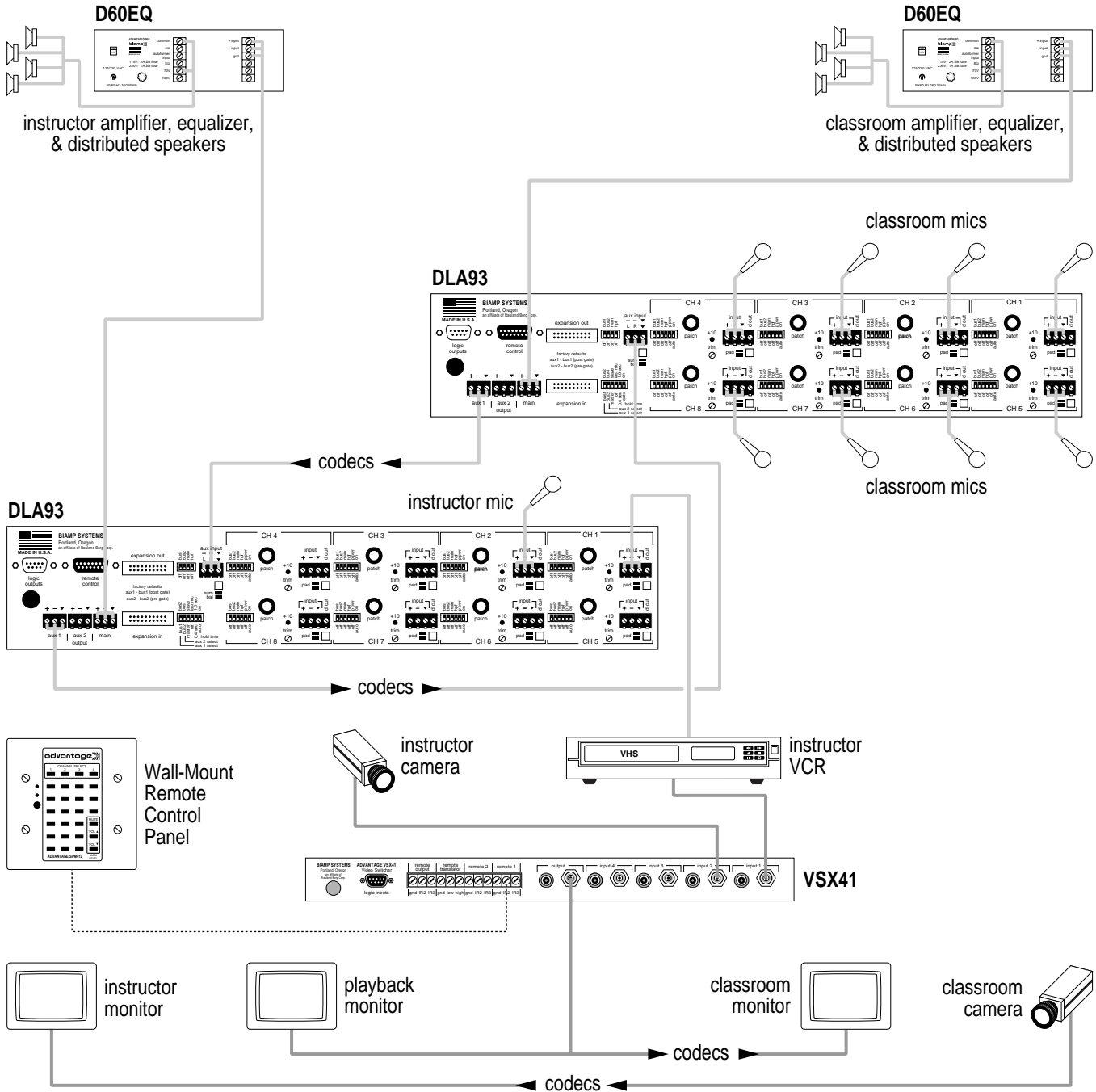

DISTANCE LEARNING

This application shows an instructor location and a classroom location. Each location has an independent sound system, with a DLA93 providing automatic mixing, and a D60EQ providing equalization & amplification for the distributed speaker system. The DLA93 at the instructor location accepts audio from the instructor mic & VCR, and from the classroom (via codecs). The sound system is assigned only VCR & classroom signals from Main Output. The codec feed to the classroom is assigned only instructor mic & VCR signals from Aux 1 Output. The DLA93 in the classroom accepts audio from the classroom mics and from the instructor location (via codecs). The sound system is assigned only instructor mic & VCR signals from Main Output. The codec feed to the instructor location is assigned only classroom signals from Aux 1 Output. These 'mix-minus' assignments avoid feedback by removing 'local' mic signals from each system. 'Mix-minus' is accomplished using the rear panel Channel DIP switches. Video signals are also sent from one location to the other (via codecs). A VSX41 at the instructor location assigns either camera or VCR video signal as the source for the classroom monitor. The instructor monitor receives video signal from the classroom camera, and the playback monitor receives video signal from the VCR.

APPLICATIONS

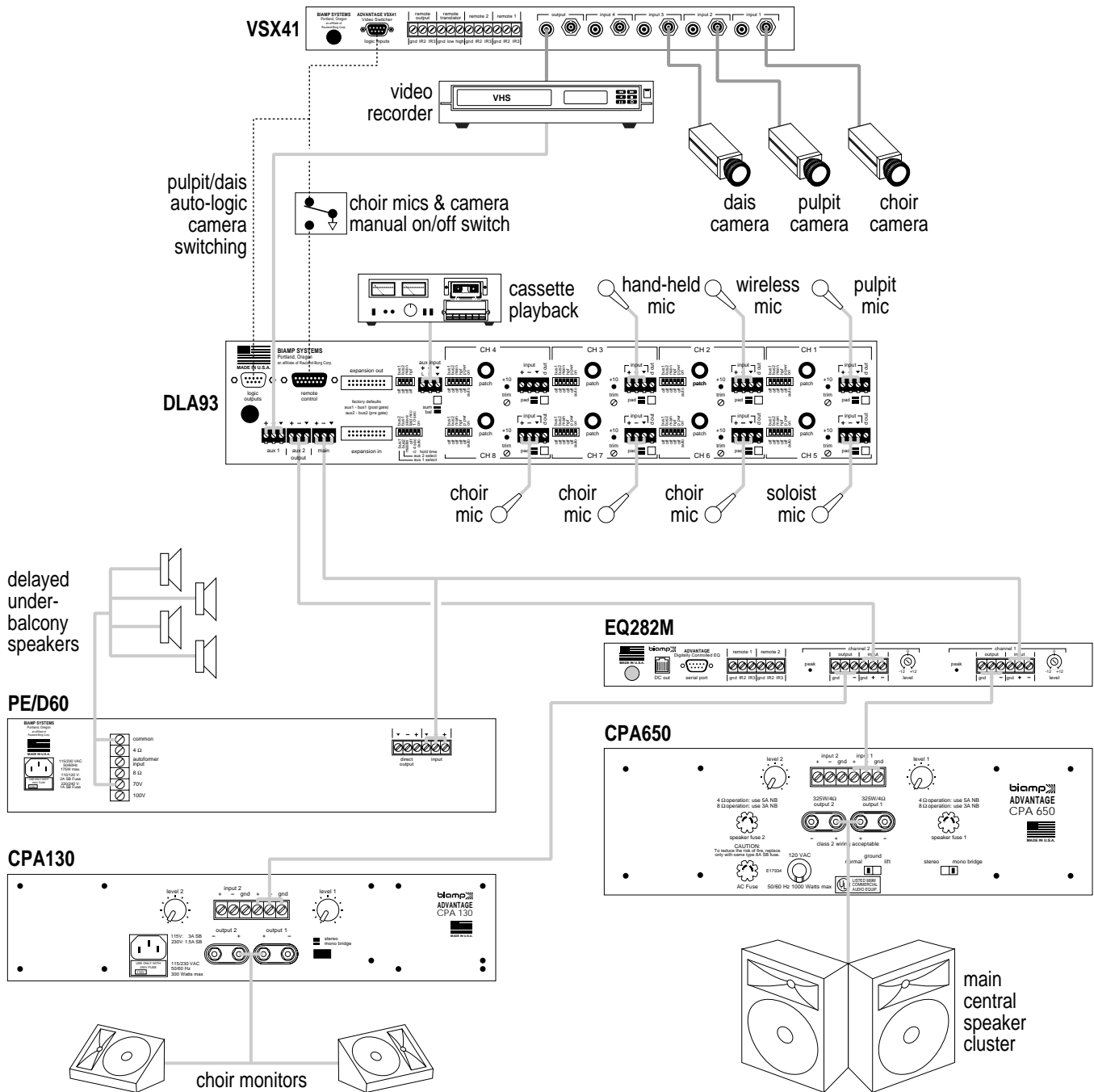

CHURCH

This application shows a church sound system, complete with video recording of the services for 'shut-in' members of the congregation. A DLA93 accepts input from choir, pulpit, wireless, & hand-held microphones, as well as a cassette deck for music playback. The pulpit, wireless, & hand-held mics are set for automatic mixing. The choir mics are set for manual mixing, and are turned on/off via a remote control switch, as necessary. A VSX41 accepts input from choir, pulpit, & dais cameras. The choir camera is selected whenever the choir mics are turned on. When the choir mics are turned off, the pulpit or dais camera is selected automatically, depending upon which mics are 'active'. The pulpit camera has priority over the dais camera, which provides a wider view when only the wireless or hand-held mics are being used. Last Mic On is selected on the DLA93 to help eliminate excessive camera switching, and to provide continuous audio to the video recorder. An EQ282M provides programmable equalization for both the main & choir monitor systems, with a CPA650 powering the main speaker cluster and a CPA130 powering the choir monitors. A PE/D60 provides delay, equalization, amplification, and an autoformer output for the 70V distributed 'under-balcony' speaker system at the rear of the church.

APPLICATIONS

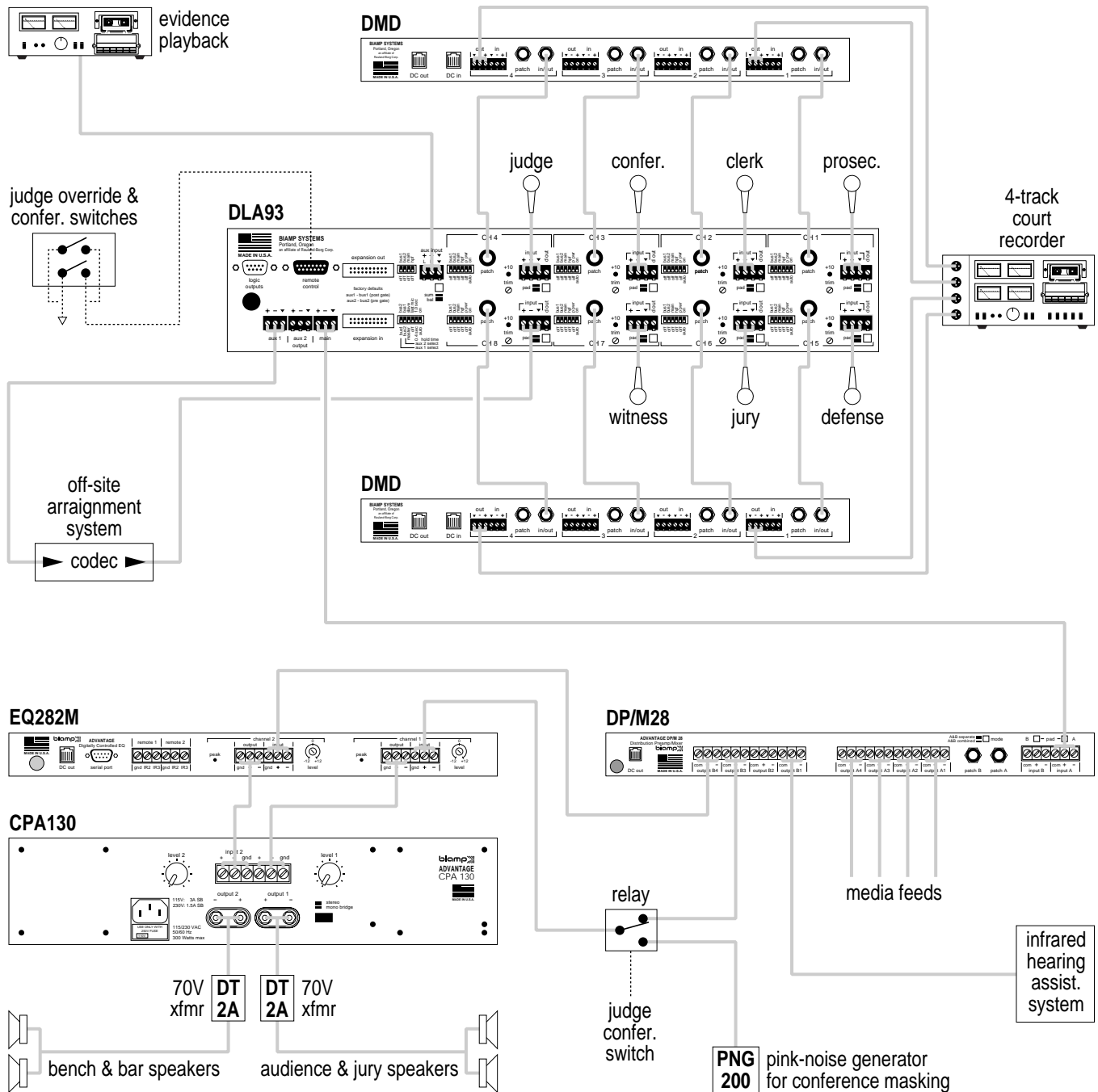

COURTROOM

This application shows a courtroom sound system, complete with recording, judge conference/override, & 'off-site' arraignment capability. A DLA93 provides automatic mixing for the courtroom microphones, and an input for playback of recorded evidence. For 'off-site' arraignment, signal from a remote location is sent (via codec) to an input channel of the DLA93, and Aux 1 Output of the DLA93 is sent (via codec) to the remote location. Aux 1 Output is assigned only courtroom signals, creating a 'mix-minus' to avoid feedback of signals to the remote location. Two DMD modules, connected to the DLA93 channel Patch jacks, provide summing and mic-level conversion of appropriate signals for the 4-track court recorder. Two switches, at the judge's bench, are wired to DLA93 Remote Control terminals. An 'override' switch mutes all inputs except the judge's mic. A 'conference' switch mutes all inputs except a special conference mic at the judge's bench. The conference mic is not assigned to any output, but is for recording purposes only. A PNG200 provides noise-masking over the audience & jury areas during conferences. A DP/M28 distributes DLA93 Main Output signal for media feeds, hearing assistance, and the sound system, which utilizes an EQ282M programmable equalizer, a CPA130 power amplifier, and two DT-2A autoformers.

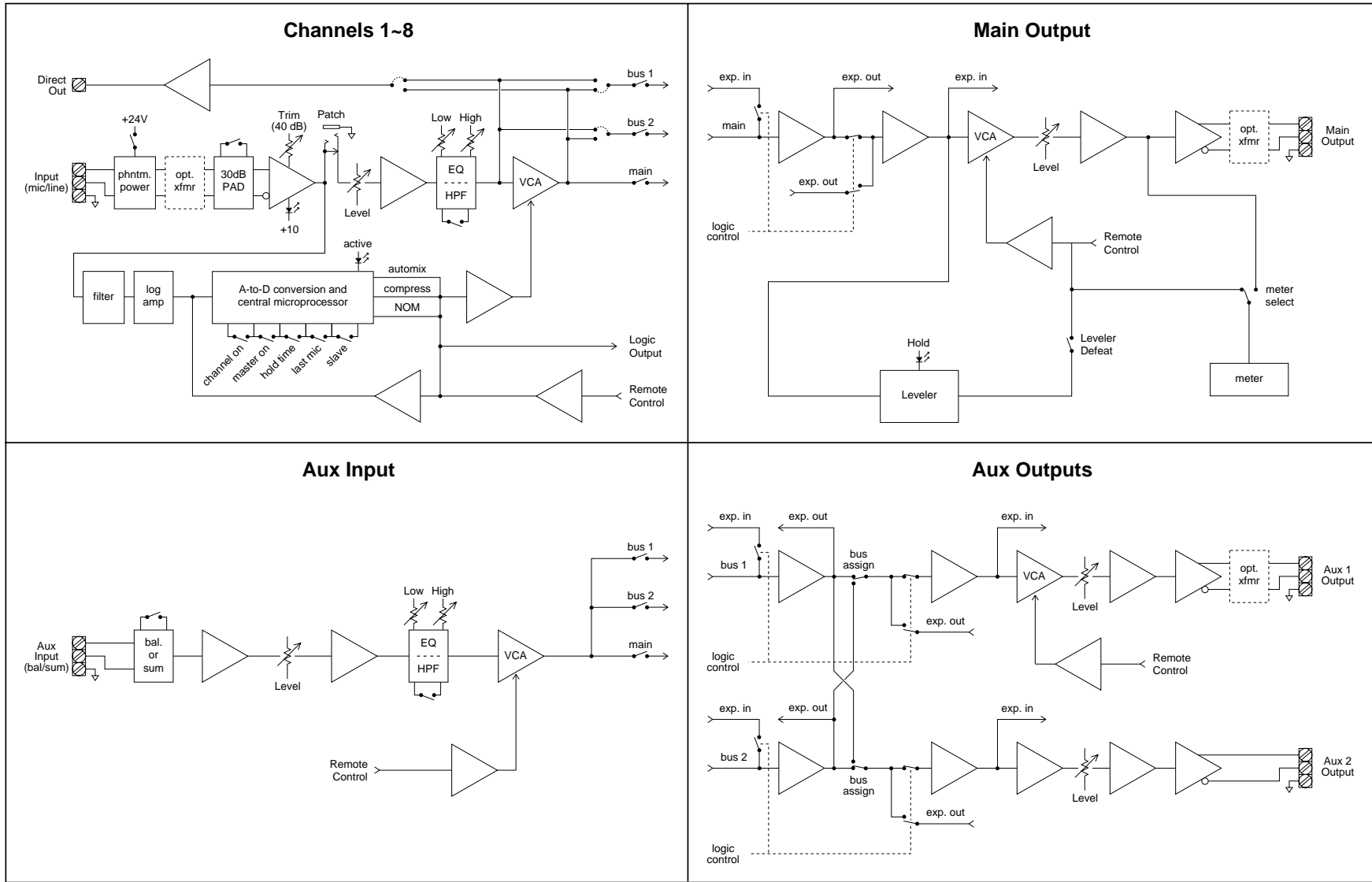

SPECIFICATIONS

Frequency Response (20Hz~20kHz @ +4dBu):	+0/-3dB
Total Harmonic Distortion + Noise (20Hz~20kHz @ +4dBu):	< 0.1%
Equivalent Input Noise (20Hz~20kHz, 150 ohm term.):	-126dBu
Output Noise (20Hz~20kHz, main & one channel @ nominal):	< -90dBu
Maximum Gain (mic input to main output):	78dB
Output Impedance:	
main & aux outputs (balanced)	< 150 ohms
channel direct out & patch (unbalanced)	50 ohms
Maximum Output:	
main & aux outputs (balanced)	+18dBu
channel direct out & patch (unbalanced)	+18dBu
Input Impedance:	
channel mic/line input (balanced)	4.55k ohms
channel patch (unbalanced)	> 7.5k ohms
Maximum Input:	
channel mic/line input (balanced)	+30dBu
channel patch (unbalanced)	+30dBu
Connectors:	
input/output	plug-in barrier
channel patch	TRS 1/4" phone
Channel Tone Controls:	
treble	±8dB @ 10kHz
bass	±8dB @ 100Hz
Channel High-Pass Filters:	
frequency	-3dB @ 170Hz
slope	6dB/octave
Main Output Leveler:	
attack time (program dependent)	0.5~0.75 seconds
release time (program dependent)	1.0~5.0 seconds
rate (program dependent)	2~20dB/second
Channel Compressors:	
attack time	30mS
release time	200mS
ratio	4:1
Power Consumption:	< 27 Watts
Dimensions:	
height (2 rack-spaces)	3.5" (89mm)
width	19" (483mm)
depth	11.5" (292mm)
Weight:	14.5 lbs. (6.58kg)

WARRANTY

BIAMP SYSTEMS IS PLEASED TO EXTEND THE FOLLOWING 5-YEAR LIMITED WARRANTY TO THE ORIGINAL PURCHASER OF THE PROFESSIONAL SOUND EQUIPMENT DESCRIBED IN THIS MANUAL.

BIAMP Systems expressly warrants this product to be free from defects in material and workmanship for a period of 5 YEARS from the date of purchase as a new product from an authorized BIAMP Systems dealer under the following conditions.

1. The Purchaser is responsible for completing and mailing to BIAMP Systems, within 10 days of purchase, the attached warranty application.
2. In the event the warranted BIAMP Systems product requires service during the warranty period, BIAMP Systems will repair or replace, at its option, defective materials, provided you have identified yourself as the original purchaser of the product to any authorized BIAMP Systems Service Center. Transportation and insurance charges to and from an authorized Service Center or the BIAMP Systems factory for warranted products or components thereof to obtain repairs shall be the responsibility of the purchaser.
3. This warranty will be VOIDED if the serial number has been removed or defaced; or if the product has been subjected to accidental damage, abuse, rental usage, alterations, or attempted repair by any person not authorized by BIAMP Systems to make repairs; or if the product has been installed contrary to BIAMP Systems's recommendations.
4. Electro-magnetic fans, electrolytic capacitors, and the normal wear and tear of appearance items such as paint, knobs, handles, and covers is not covered under this warranty.
5. BIAMP SYSTEMS SHALL NOT IN ANY EVENT BE LIABLE FOR SPECIAL, INCIDENTAL, OR CONSEQUENTIAL DAMAGES, INCLUDING LOST PROFITS, LOSS OF USE, PROPERTY DAMAGE, INJURY TO GOODWILL, OR OTHER ECONOMIC LOSS OF ANY SORT. EXCEPT AS EXPRESSLY PROVIDED HEREIN, BIAMP SYSTEMS DISCLAIMS ALL OTHER LIABILITY TO PURCHASER OR ANY OTHER PERSONS ARISING OUT OF USE OR PERFORMANCE OF THE PRODUCT, INCLUDING LIABILITY FOR NEGLIGENCE OR STRICT LIABILITY IN TORT.
6. THIS WARRANTY IS IN LIEU OF ALL OTHER WARRANTIES EXPRESSED OR IMPLIED. BIAMP SYSTEMS EXPRESSLY DISCLAIMS ALL IMPLIED WARRANTIES OF MERCHANTABILITY AND FITNESS FOR A PARTICULAR PURPOSE. THE REMEDIES SET FORTH HEREIN SHALL BE THE PURCHASER'S SOLE AND EXCLUSIVE REMEDIES WITH RESPECT TO ANY DEFECTIVE PRODUCT. THE AGENTS, EMPLOYEES, DISTRIBUTORS, AND DEALERS OF BIAMP SYSTEMS ARE NOT AUTHORIZED TO MODIFY THIS WARRANTY OR TO MAKE ADDITIONAL WARRANTIES BINDING ON BIAMP SYSTEMS. ACCORDINGLY, ADDITIONAL STATEMENTS SUCH AS DEALER ADVERTISEMENTS OR REPRESENTATIONS DO NOT CONSTITUTE WARRANTIES BY BIAMP SYSTEMS.
7. No action for breach of this warranty may be commenced more than one year after the expiration of this warranty.

Thank you for purchasing BIAMP SYSTEMS...
AMERICAN SOUND CRAFTSMANSHIP

Biamp Systems
10074 S.W. Arctic Drive
Beaverton, Oregon 97005 U.S.A.
(503) 641-7287
<http://www.biamp.com>